



LED SOLAR GARDEN LIGHT

โคมไฟสวน LED โซล่าเซลล์

รุ่น BEAN STALK SERIES



ทางเลือกใหม่
สำหรับการ
ประหยัดพลังงาน



ผลิตภัณฑ์ มีสเดอริลูเมน | จัดจำหน่ายโดย บริษัท ชันคอรี เว็นเนอริซี่ จำกัด

LUMENS

โคมไฟสวน LED โซล่าเซลล์

EMS(energy management system)ensure light up 10 days in rainy weather

IP66 waterproof

Replaceable Lithium-ion batteries pack

21% conversion rate solar panel

Dual lens system 360 degree lighting distribution

PIR motion sensor save energy

MPPT charging technology



PARAMETERS

Model No.	BST-16
Solar Panel	25W
Light Power	16W
Battery	138.8WH
Luminous flux	2500lm
Recommended installation height	3-5m.
Recommended mounting distance	10-20m.
Warranty	2 Years (Lifetime 6-8 years)
LED Chip	
CCT	5000K-6500K
Beam angle	360 degree
Battery backup time	3 days
Dim mode	First 5 hours : 50% brightness, last 5 hours in dimming mode (100% with people, 20% without people)
Working temperature	-20°C to 60°C
Charging time	9-11 hours
Required pole size	60 mm (top end)



โคมไฟสวน LED โซล่าเซลล์

Product size and Packing info

Unit : mm

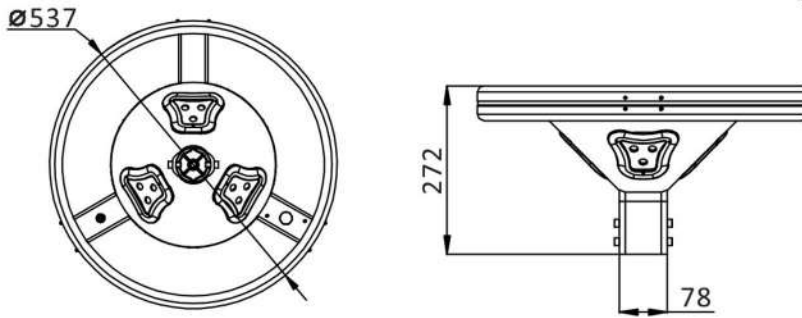

Model No.	Qty	Carton Size	N.W.(kgs)	G.W.(kgs)	20ft container	40ft container
BST-16	1pcs/ctn	640*640*345mm	8	11	16	432

Applications

Widely used in the road, street, factory, park road, rural, mountainous area and the remote area lighting project, courtyard, schools, square and other need to place for outdoor lighting



บริษัท มีสเดอริลูเมน | จัดจำหน่ายโดย บริษัท ชันคอรี เว็นเนอริบี จำกัด



Distributed by

SUNKOR ENERGY CO., LTD.

10 Sopha Village, Soi Ngamwongwan1/1,
Bang Kraso, Nonthaburi 11000

